

# 100Gb/s CFP Optical Transceiver



## Standards

- 
- 
- 
- 
- 

## Ordering Information

Part No	Specifications	Application
		Code

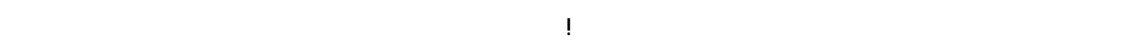

!







**Note2:**

## **Hardware Alarm Pins**



--	--	--	--	--	--













--	--	--	--	--	--	--	--	--	--





--	--	--	--	--	--	--	--



--	--	--	--	--	--	--



---



		RO/LH/COR				
		RO/LH/COR				
		RO/LH/COR				
		RO/LH/COR				













Table : CFP Pin-Map

<b>PIN#</b>	<b>Top Row</b>	<b>PIN#</b>	<b>Bottom Row</b>	<b>PIN#</b>	<b>Top Row</b>	<b>PIN#</b>	<b>Bottom Row</b>
	<b>(2nd</b>		<b>(2nd Half)</b>		<b>(1nd</b>		<b>(1nd Half)</b>
	<b>Half)</b>		<b>Name</b>		<b>Half)</b>		<b>Name</b>
	<b>Name</b>				<b>Name</b>		









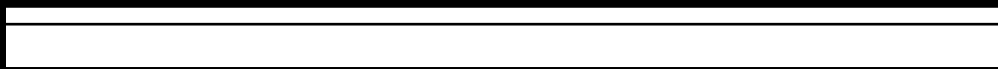

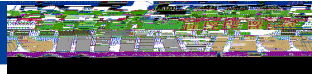
# Block diagram



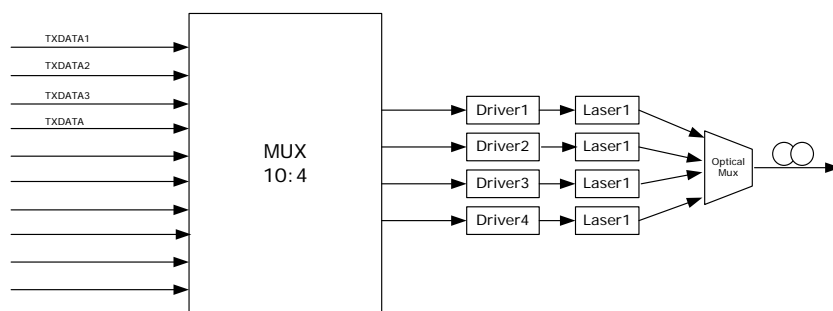

# Package outline

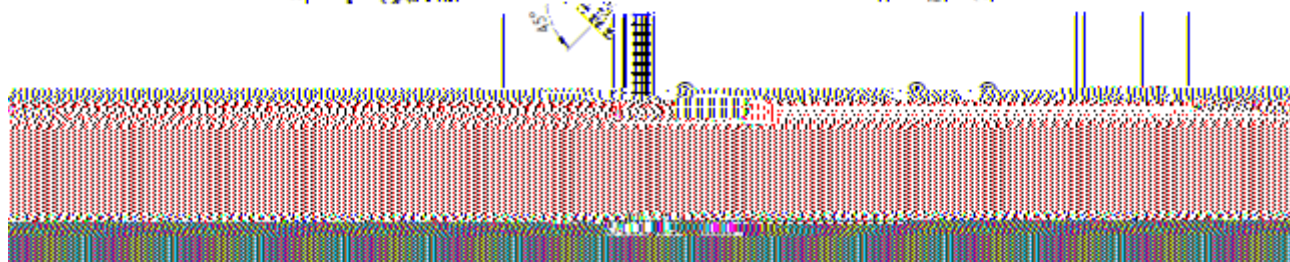
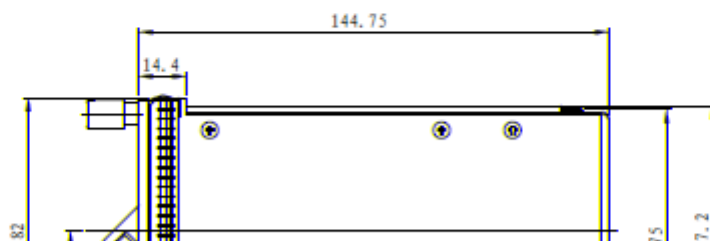
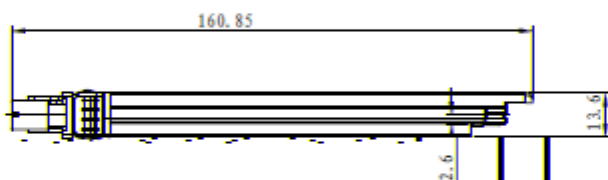
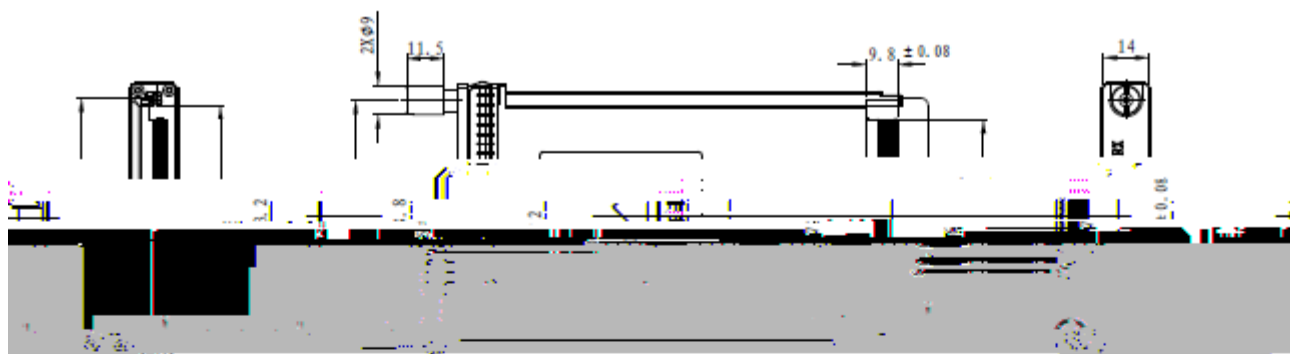



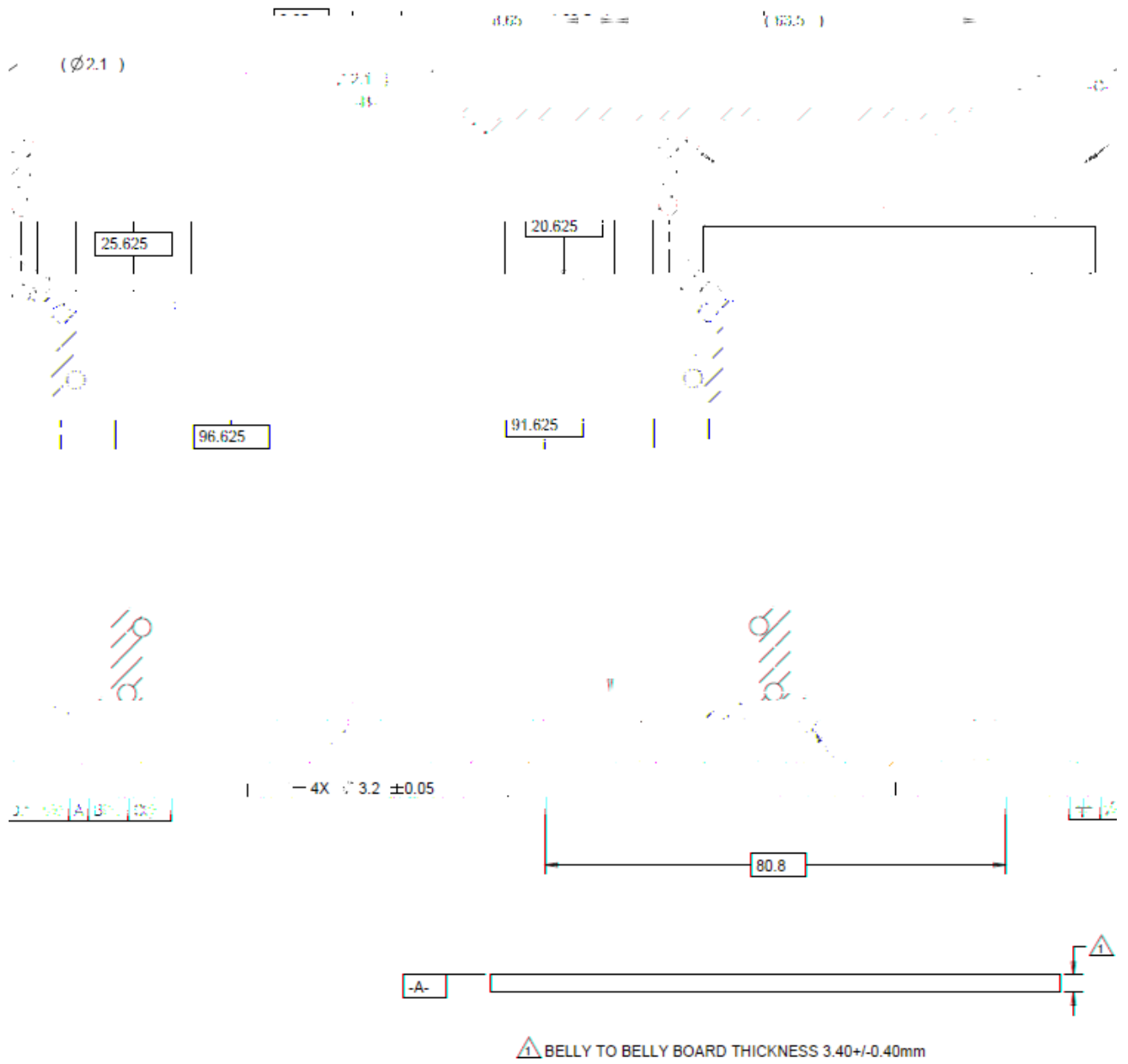

FIGURE 21



## Regulatory Compliance

Feature	Test Method	Performance
[Empty table body]		

