

XGS-PON ONU Optical Transceiver SFP+ Module

The XGS-PON ONU Transceiver is designed for 10G XGS-PON transmission. The module incorporates 10Gb/s 1270nm burst-mode transmitter and 10Gb/s 1577nm continuous-mode receiver. An integrated WDM coupler can separate 1577nm input light and 1270nm output light. The metallic package guarantees excellent EMI and EMC characteristics, which totally comply with international relevant standards.

Specifications

(tested under recommended operating conditions, unless otherwise noted)

Parameter	Symbol	Unit	Value		
			Min	typical	Max
Electrical Characteristics					
Power Consumption		W	-	-	2.0
LVPECL Single Ended Data Input Swing		mV	100	-	800
CML Single Ended Data Output Swing		mV	300		500
Differential Data input impedance			-	100	-
Signal Level(LVTTL)	VOH	V	2.4	-	Vcc
	VOL	V	0	-	0.8
Optical transmitter Characteristics					
Data Rate		Mbps	--	9953	-
Center Wavelength Range	c	nm	1260	-	1280
Spectral Width(@ -20dB)		nm	-	-	1

XGS-PON ONU Optical Transceiver SFP+ Module

Absolute Maximum Ratings

Parameter	Symbol	Unit	Min	Max
Storage Temperature Range	T_s	$^{\circ}\text{C}$	-40	+85
Relative Humidity	RH	%	5	95
Power Supply Voltage	V_{cc}	V	0	+4
Receiver Damage Threshold		dBm	+0	-

Recommended Operating Conditions

Parameter	Symbol	Unit	Min	Typ	Max
Operating Case Temperature Range	T_c	$^{\circ}\text{C}$	0	-	70
Power Supply Voltage	V_{cc}	V	3.135	3.3	3.465

Principle diagram

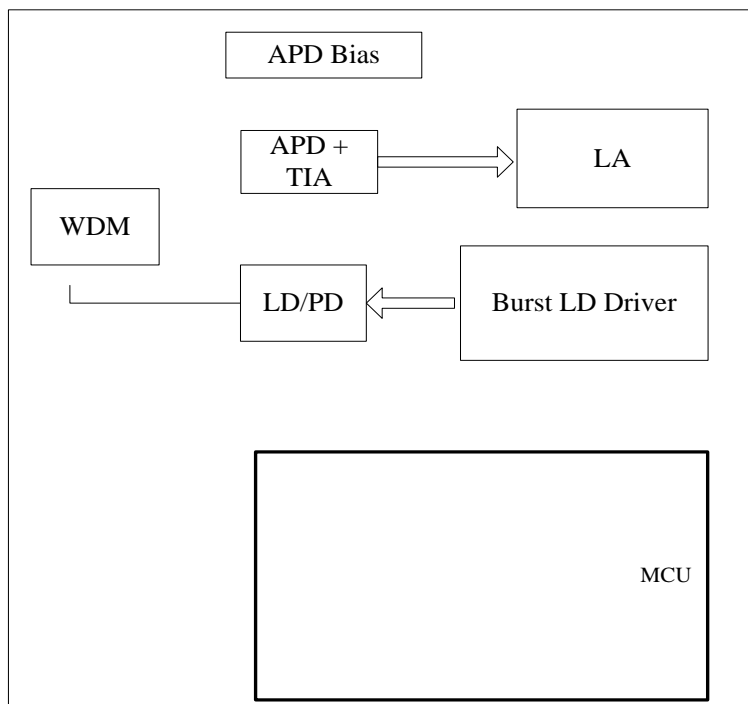

Optic Ports Definition

Single SC receptacle optical interface



XGS-PON ONU Optical Transceiver SFP+ Module

Product appearance and Label

Regulatory Compliance

Feature	Test Method	Performance
Electrostatic Discharge (ESD) to the Electrical Pins	MIL-STD-883E Method 3015.7	Class 1 (>1.5kV) Human Body Model
Electrostatic Discharge (ESD) Immunity	IEC61000-4-2	LV4(Air discharge 15kV,Contact discharge 8kV) Performance criterion B
Electromagnetic Interference (EMI)	CISPR22 ITE Class B EN55022 Class B	Compliant with standards
Immunity	IEC61000-4-3 Class 34 0.4	



XGS-PON ONU Optical Transceiver SFP+ Module

Update Information

