

XGPON1 OLT Transceiver XFP Module

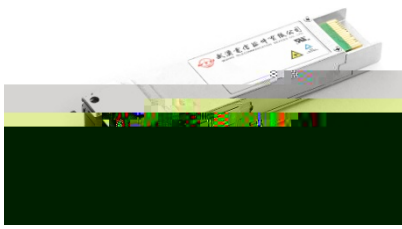

RTXM266-702 product is designed for OLT module based on XGPON technology. The product is an integrated module containing a micro-optic component and semiconductor material. The module could implement DDM function. It could be used at key locations in optical networks.

Features

- ' XFP package with SC receptacle optical interface compliant
- ' Hot-Pluggable
- ' 9.953Gbps downstream and 2.488Gbps upstream
- ' +3.3V single power supply
- ' ROHS Compliant

Applications

- ' Optical transceiver for N2a XGPON OLT

Standards

- ' ITU-T G.987
- ' MSA SFF-8077iv4.5

Specifications

Parameter	Symbol	Unit	Value		
			Min	typical	Max
Electrical Characteristics					
Supply Current	Icc	mA			

					+8
Center Wavelength Range	c	nm	1575	1577	1580
Extinction Ratio -10G	EX	dB	8.2		
Spectral Width(@ -20dB)		nm			1
Side Mode Suppressing Ratio	SMSR	dB	30		
Eye Diagram	Complies with G.987.2				
Dispersion Penalty	-	dB			1.0
Pout @ TX-Disable Asserted	Poff	dBm			-39
Optical receiver Characteristics					
Receiver Optical Wavelength	IN	nm	1260	1270	1280
Receiver Sensitivity (note3)	S	dBm			-29.5
Overload Input Optical Power	Pin	dBm	-7		
SD Assert		dB			-30
SD De-assert		dB	-45		
Receiver Settling Time		ns			64
1. AC coupled internally; 2. DC coupled internally; 3. Measured with a PRBS 2 ²³ -1 NRZ test pattern, @2.488Gb/s, EX=9dB, BER<10 ⁻⁴ .					

Ordering Information

PartNo	Specification								
	Package	Data rate	Laser	Power	Detector	Sensitivity	Temp	Reach	Other
RTXM266-702	XFP SC	9.953/2.5	EML	+4~+8dBm	APD	< -29.5dBm	0-70	20km+	RoHS DDM

XGPON1 OLT Transceiver XFP Module

Absolute Maximum Ratings

Parameter	Symbol	Unit	Min	Max
-----------	--------	------	-----	-----

Recommended Operating Conditions

Principle diagram

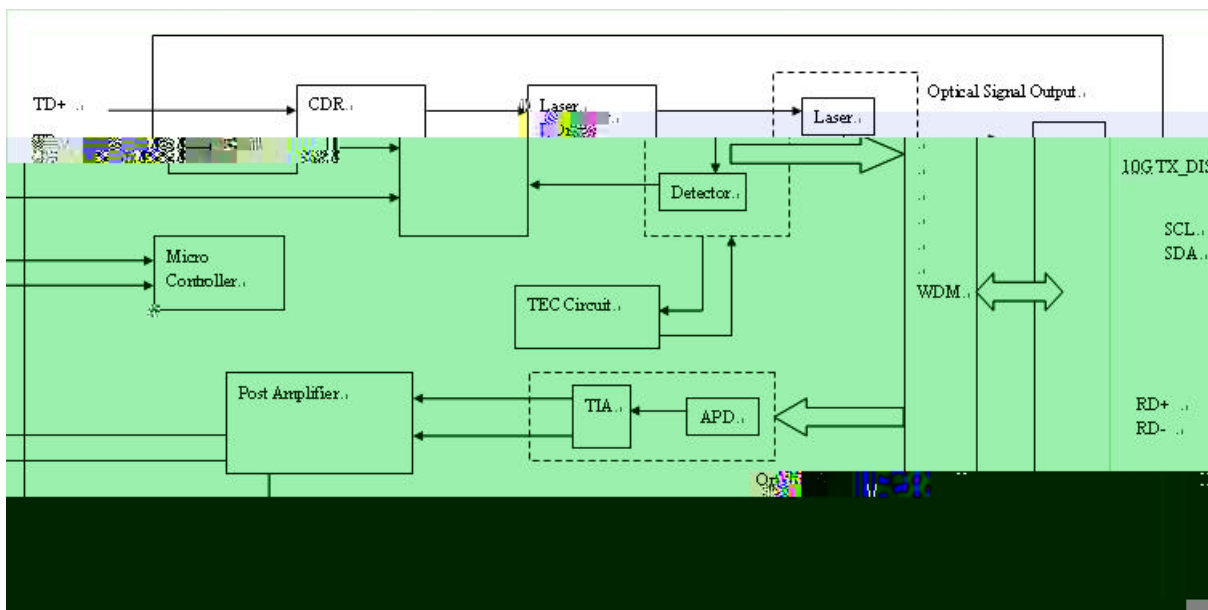

Electric Ports Definition

XGPON1 OLT Transceiver XFP Module

Regulatory Compliance

Feature	TestMethod	Performance
RoHS	BSEN 1122:2001 USEPAMETHOD3050B USEPAMETHOD3052 USEPAMETHOD3060A	Pb <1000ppm Cr6+ <1000ppm Hg <1000ppm PBB <1000ppm PBDE <1000ppm Cd <100ppm
Electrostatic Discharge (ESD) to the Electrical Pins	MIL STD 883E Method 3015.7	Class1 (>1.5kV) Human Body Model
Electrostatic Discharge (ESD) Immunity	IEC 61000-4-2	Class2 (>4.0kV)
Electromagnetic Interference (EMI)	CISPR 22 Class B FCC Class B CENELEC EN 55022 VCCI Class 1	Compliant with standard
Immunity	IEC 61000-4-3 Class 2	Typically show no measurable effect from a 3V/m field swept from 80 to 1000 MHz applied to the transceiver without a chassis enclosure.